TrendWall[®]

Planning Guide

December 2020

Contents

Six steps to specification	3
Design and Installation Planning	4-9
Components.....	10
Framing Elements.....	11
Panels	12 - 17
Door Sections.....	18 - 19
Doors	20 - 21
Door Hardware.....	22
Conditions.....	23 - 26
Pilasters.....	27 - 28
Accessories.....	29
Power and Data	30 - 33
Acoustics	34 - 35
Installation Information.....	36

TrendWall® Movable Wall

Proven for Over 50 Years

For over 50 years, Trendway Movable Walls have been used in floor-to-ceiling applications around the world. TrendWall's simple installation minimizes downtime and practically eliminates mess and waste. It can be rapidly reconfigured without demolition, using only a handful of trades. A proven performer, TrendWall responds with ease to support an organization's changing needs.

TrendWall offers flexible architectural planning, expanded capacity for utility and technical infrastructure, and integration with both existing building infrastructure and systems furniture. With a broad palette of standard surface materials and finishes, plus the ability to support a wide range of custom and special materials, TrendWall can seamlessly harmonize throughout an environment.

TrendWall is BIFMA level® 2 certified and with SCS Indoor Advantage Gold™ certified components. TrendWall, Volo® and Clear Wall are the premier sustainable architectural walls on the market.

Six steps to specifications:

1. Pre-qualify the project
2. Select Panel types
3. Select Door Section
4. Specify Conditions Connectors
5. Specify Electrical and Data components
6. Specify Accessories and Miscellaneous Components/Connectors

Design and Installation Planning

Proper planning and preparation is key to successful and profitable TrendWall projects. Begin by taking the time to fully understand the customer's needs and requirements. Have their Request for Bid documentation on hand when performing site surveys and during design and installation. It is critical to document all decisions made from start to finish.

Trendway field support

Trendway offers Field Technical Support for a nominal fee. Approved Trendway Technicians can take field measurements, train and lead during the actual installation at the customer location. Using this resource assures accurate product design and planning, as well as fast, expert installation. Contact the Trendway Architectural Product team for more details.

Site survey and verified field measurements

- A thorough pre-installation survey is required.
- Ensures fast, accurate, effective space planning and design.
- Allows effective scheduling for timely completion, no lost time on the job.
- Improves profit through problem-free installations, happy customers and return business.

Floor plans

Accurate floor plans with key dimensions and conditions within the building architecture are essential. They should include:

- Overall space dimensions
- Wall locations and distance from columns
- Wall runs that terminate flush with building wall surfaces
- Existing corridor widths and runs that bypass building columns

Getting Started

- Use the AP Project File tool to generate pricing for customer approval.
- TrendWall measurements are based on centerline-to-centerline locations (e.g., center panel to center panel vs panel edge to panel edge).
- Begin by defining the location of the partition run. TrendWall Vertical Connectors are 2-3/4" thick, so using construction lines that are offset by 1-3/8" is a good place to start (center of panel). Wall Starts and condition connectors are consistently 2-3/4" thick.
- Once the desired location of the walls is determined, you can begin the room layout.
- The framing layout and elevations can be developed using 2020 CAP planning software supported with Trendway symbol libraries.

Ceiling height - a critical measurement

- **Measurements must be taken on the final site floor treatment (after carpet or other flooring is installed) for accuracy.**
- **IMPORTANT: Measure ceiling height at every door location.**
- Measure ceiling heights every 10', approximately along the line the wall will run.
- If there is variance greater than 1/2" over a 10' measurement, take additional measurements at 5' intervals.
- **Provide minimum and maximum heights.**
- Note all heights accurately on the floor plan in 1/8" increments.

Site Ceiling

Determine the installation site's ceiling type and grid (if applicable), which will determine attachment requirements. If you are not certain, or encounter a different type of ceiling than described here, send a photo to your Trendway Technical Support team for assistance.

Information you will need:

- Identify ceiling type: Grid and Tile, Gypsum or other material (e.g. wood). This will determine the type of ceiling anchors you require.
- Identify Grid ceiling tile type (if applicable):
 - Flat
 - Tegular/Reveal
 - Armstrong Silhouette
- Tegular/Reveal grids require the use of Grid Blocks for installation. Determine if the Tegular tile has a 1/4" or 3/8" tile recess dimension (how high it sits proud of the grid). There are Grid Blocks for Traditional and Reveal style crowns. Specify the 1/4" or 3/8" Block, depending on the tile recess. Specify one Block for every 2' of panel run, or 6 for every Crown section on order.
- Identify Grid type (if applicable): 1" Standard or 9/16" Thinline

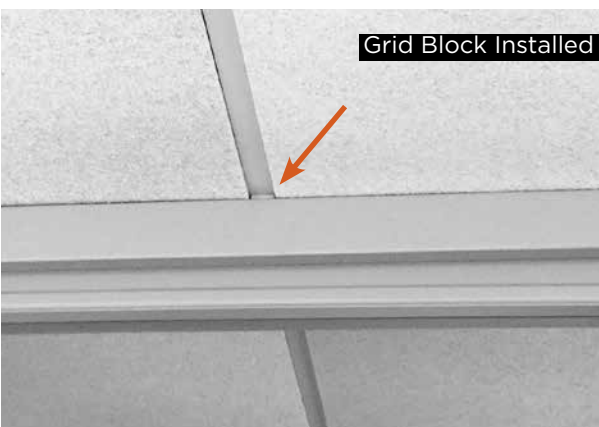

Site Ceiling

TrendWall Crown elements are secured to the ceiling or ceiling grid using appropriate fasteners.

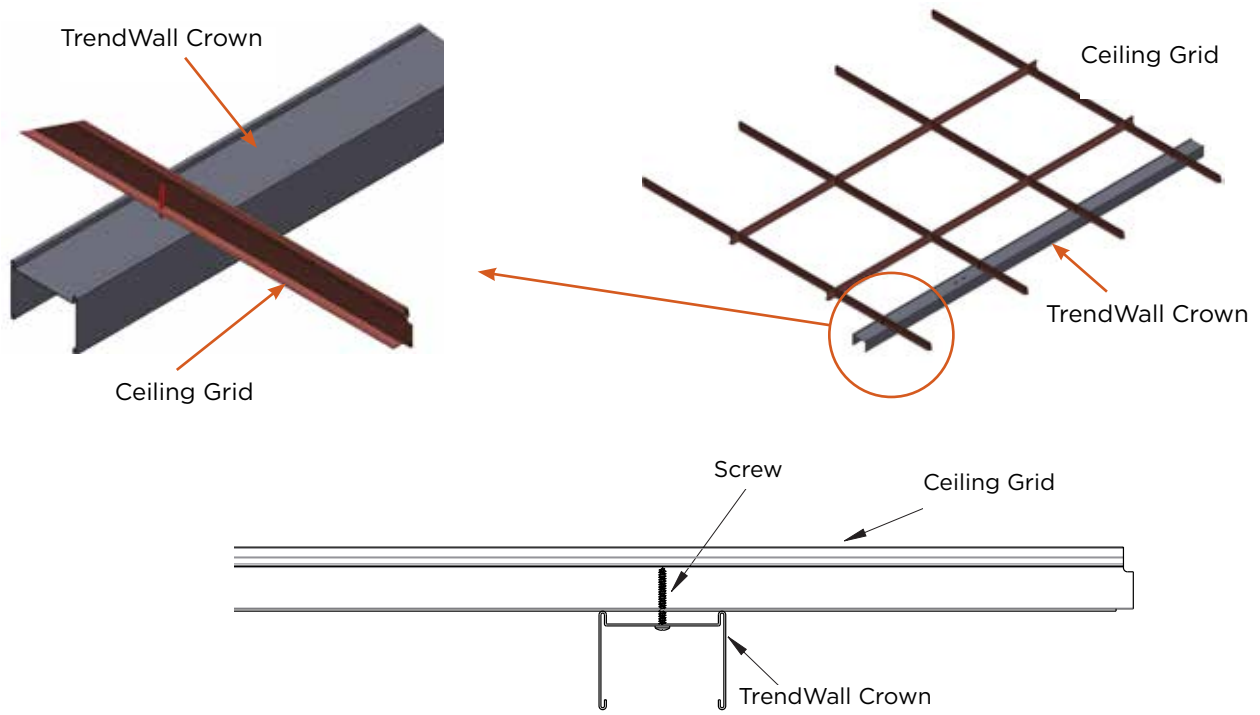

Armstrong Silhouette ceiling requires the use of Grid Clips to attach the Crown to the grid, available for order from Trendway (Special part number 404765).

Caddy Clips may be used to attach the Crown to many ceiling grids. Use one every 2' of Crown. **Caution:** There will be a loss of 1/2" to 5/8" ceiling height adjustment when using Caddy Clips.



Physical building conditions

Site conditions may affect wall placement or require special planning to accommodate. Inspect the site and note any situations that may impact or interfere with the layout, such as:

- Building walls and columns
- Building electrical and data access
- Convector Units (baseboard heating units)
- Perimeter Wall Start Conditions
- Air-handling diffusers
- Floor Type HVAC Supply and Return Grills
- Light fixtures
- Soffits
- Sprinkler heads
- Unusual Baseboard Configurations
- Wall or floor outlets
- Window Fillers
- Ceiling type
- Flooring type
- Window sill and drapery pockets

Once the site observation and measurements are complete:

- Identify any design modifications that should be anticipated due to site conditions.
- Review modifications with the designer before any design or layout begins
- Review modifications with the installers before installation work begins.

Once the design is finalized, it's essential to do a thorough onsite verification of the installation drawings to actual site dimensioning prior to installation.

Compliance with relevant regulations

Before any work is performed, be certain you are in compliance with local and/or Government project or contract regulations. These may include, but are not limited to:

- Building Codes
- Building Permits
- Test data or product sample submissions for approval
- Certificates of Occupancy
- Labor requirements (security clearance, trade union jurisdictions for tasks, etc.)
- Dealer- or customer-supplied verification of seismic bracing if required by local code

TrendWall Office Layout

When designing your layout, it is best to work in standard dimensions of even footage. An example is shown in the sample layout (Figure 1): 15' by 10'.

An important consideration is the cost of the different panel types and sizes. The most cost-efficient size is the 4'-wide panel. It takes less time to install 12 lineal feet of 4' panels than 12 lineal feet of 2' panels. Also, for future changes, standard width panel modules will make modifications easier.

The first step is to measure the perimeter dimension of the space to be enclosed. Be sure to measure through door sections and glazed panels. This represents the total footage of TrendWall panels required.

Panel widths are based on center-to-center of the connection device so there is no addition of width in a straight line connection. TrendWall panels are 2-3/4" thick. Half this thickness, (1-3/8") must be added to the length of the panel run for an outside dimension, or subtracted for an inside dimension when panels are joined in a 90° corner condition (Figure 2).

Once you have decided the amount of space and the components desired, you will need to figure the widths of panels needed to achieve your room plan. Notice that we have used two 4'- wide panels to accommodate the Lateral Files side-to-side (Figure 1). 1'-wide panels on either end of that wall make up the rest of the 10' width and center the components on the wall. Minimum width panel available is 6".

NOTE: Freestanding applications

When planning for a TrendWall application that is not attached to a ceiling, additional components are required to provide the additional structural integrity required for freestanding capability:

- Ceiling Brace, Round (TCBRACERE)
- Ceiling Brace, Square (TCBRACESQ)
- Freestanding Stabilizing Block (WB-10552)

Round Ceiling Braces are specified for inline panels, and Square are specified for end-of-run conditions. Stabilizing Block is ordered in 8' lengths. Quantities required are based on the specific layout. **This method adds the rigidity necessary for a freestanding wall up to a 12' run. If you desire other dimensions, contact your Trendway Architectural Specialist and design team for help. NOTE: Furniture products can NOT be mounted on TrendWall in freestanding applications.**

Figure 1

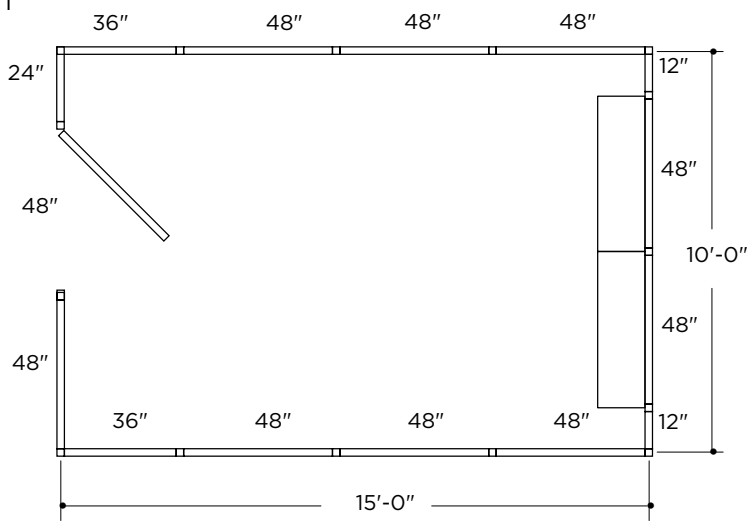
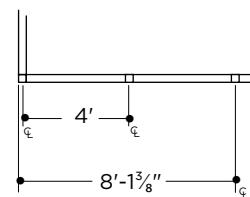

Figure 2



Installation planning checklist

- ___ Where will material be received, and who will receive?
- ___ Where will material be stored?
- ___ Are there any access or security rules governing time that installation may take place?
- ___ Where are walls to be installed?
- ___ Is the environment (i.e. heat, light, humidity, etc.) satisfactory?
- ___ Are there any power complications?
- ___ Are there any material handling obstacles (e.g. elevator/stairwell/corridor dimensions)?
- ___ What preparation is required for cleanliness of metal trim and panel cutting?
- ___ Are there any special tools or equipment required? (See Recommended Installation Tools list on page 36.)
- ___ Are there complications or timing conflicts with other trades?
- ___ Are floor loading limitations satisfactory?
- ___ Ceiling type (drywall, drop Flat, drop Tegular/Reveal etc.)?
- ___ Is there anything on this job that requires extraordinary preparation?

Post-Installation

- Obtain post-installation verification of product delivery, ownership, and security.
- Complete any punch list items and “turnover” procedures (Certificate of Occupancy, etc.).
- If promotional photography is desired, obtain permission (signed release) and schedule.

TrendWall Components

TrendWall is a simple wall system with few major components:

- ① Framing Elements
- ② Panels
- ③ Doors
- ④ Conditions
- ⑤ Finish and Trim
- ⑥ Power and Data

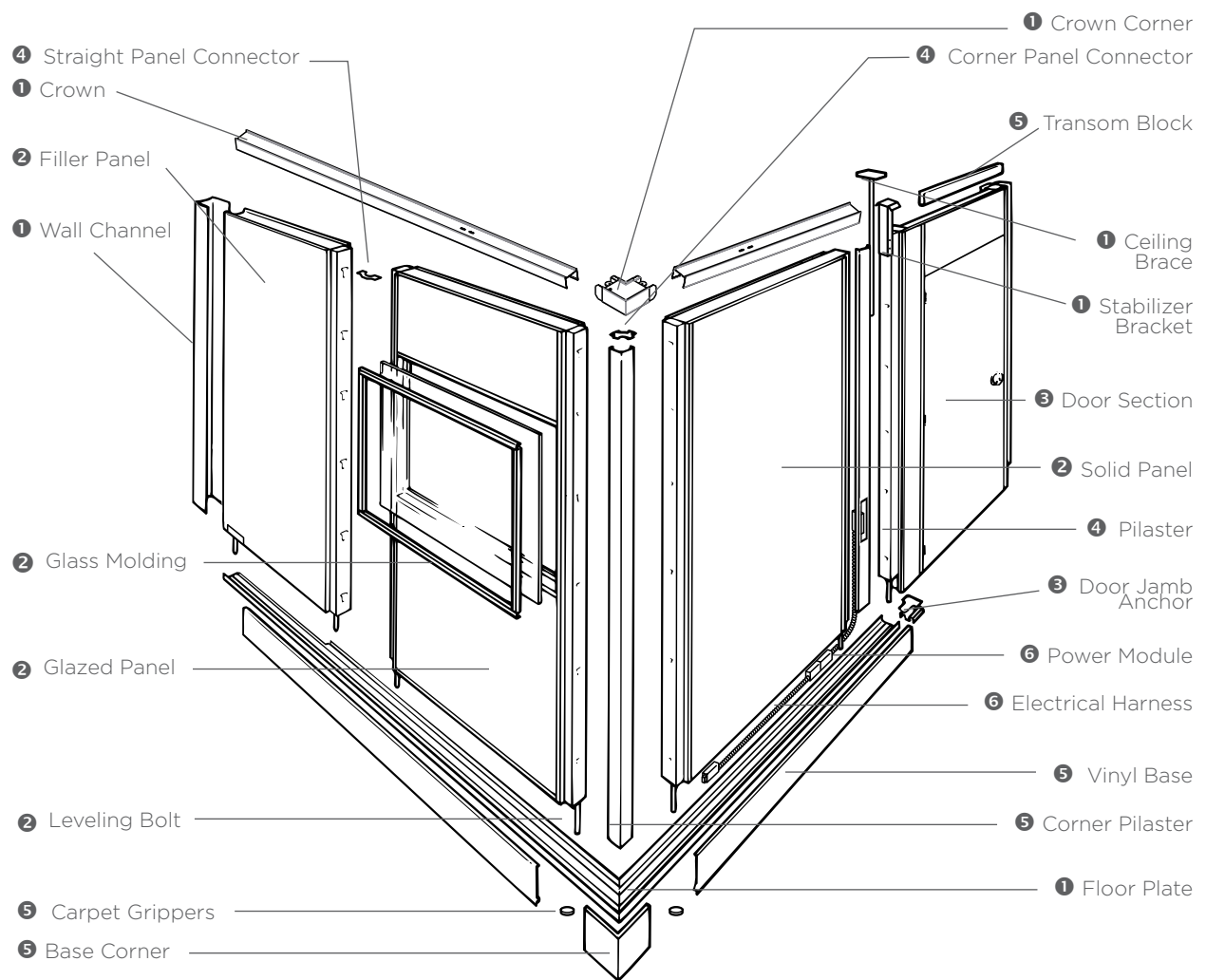

Framing Elements

Crown | Made of 18-gauge roll-formed steel, the crown is the U-shaped ceiling channel that holds each panel in place. The crown can be screwed or clipped to the ceiling grid with caddy clips that hold the crown without defacing the grid itself.

Wall Channel | The Vertical Wall Channel is used with a Filler Panel at the end of a panel run to create a clean finish against an existing building wall. It can be used to accommodate field conditions such as mullions, moldings or other dimensional variations.

Floor Plate | The Floor Plate is a channel made of 20-gauge roll-formed steel that aligns and supports the panel at the floor. The Vinyl Base attaches to this channel.

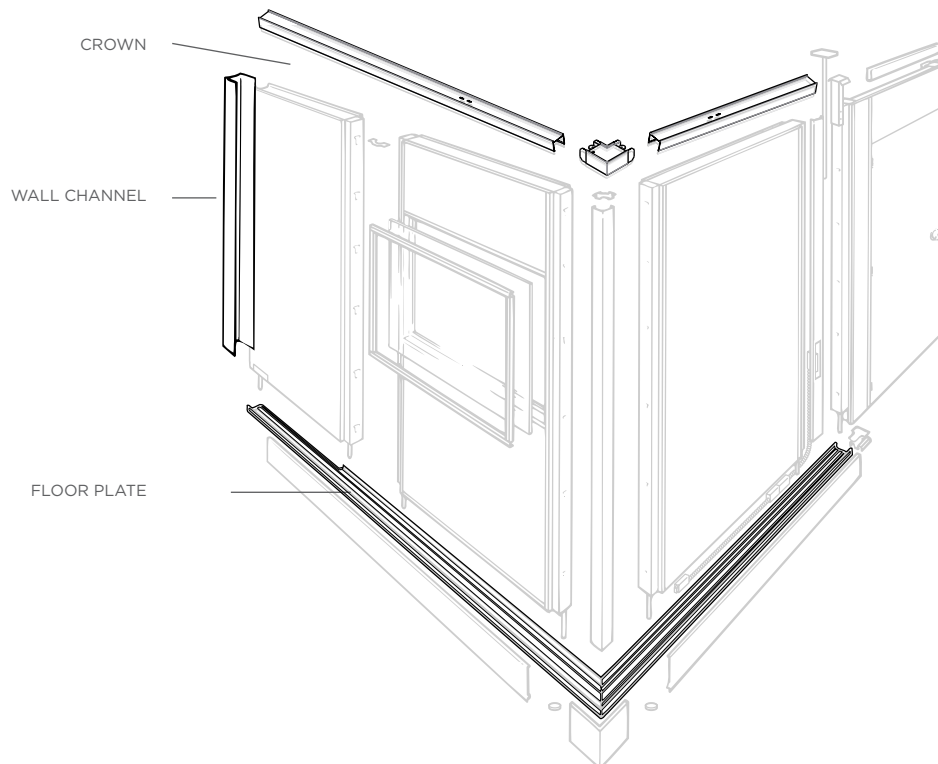
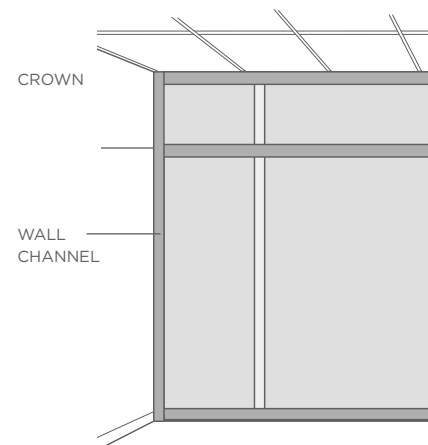

Panels

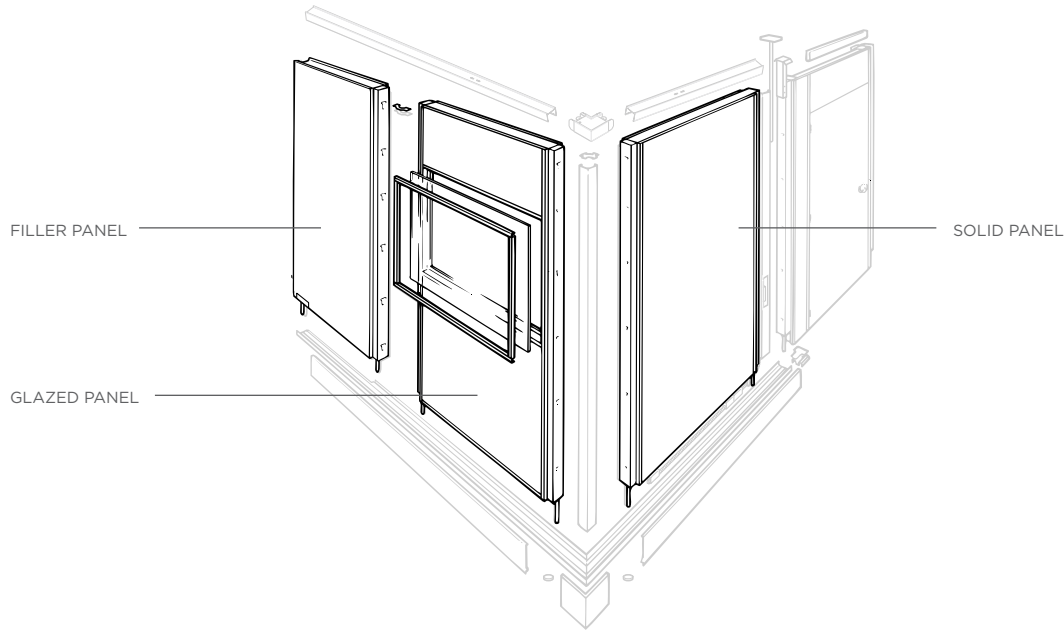

Panel Height | TrendWall panels are categorized in three standard heights, 8' and less, 9' and less, 10' and less. Within those sizes they can be specified in 1/8" increments for dimensions from 7' to 10' high. The maximum height for a freestanding installation is 10'. Ceiling Panels and Crown Filler Blocks can also create additional height for supported panels (see below). TrendWall panels have an adjustable base that accommodates adjustment 3/4" up or 3/4" down. Specify ceiling height in inches using a decimal to represent fractions in eighth-inch increments.

Panel Width | TrendWall panels are available in 1/8" increments from 6" to 4' wide. The most cost-efficient panel is 4' wide. Specify panel width in eighth-inch increments. Nominal Panel width is measured center-to-center of the connecting Pilasters (see below).

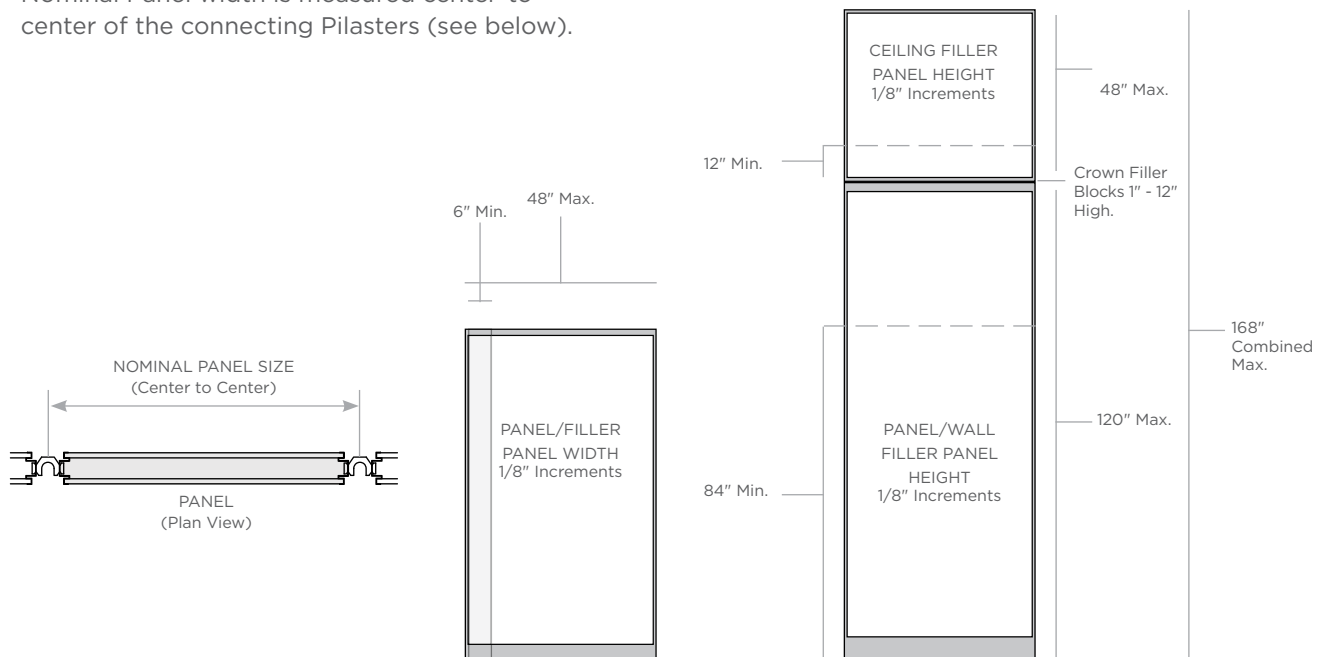

Solid Panels | Solid panels are fabric or vinyl clad 3/8" gypsum surface, available in a wide variety of fabrics and vinyl, or may be specified with Customer's Own Material (COM). [See complete COM process details in the Price List.](#) Panels can be specified with vinyl on one side and fabric on the other. All visible metal surfaces on the panel are finished with powder-coated paint, available in all standard Trendway trim color options. See the Surface Material pages of the current Price List for detailed surface material options.

Solid Panel Louver Options

Aluminum painted louvers can be added to any Solid Panel at least 36" wide. The Louver opening is nominal 11" x 27". Louvers are powder-coat painted to match the chosen Trim Color.

P0 - No Opening

P1 - Aluminum Louver Top

P2 - Aluminum Louver Bottom

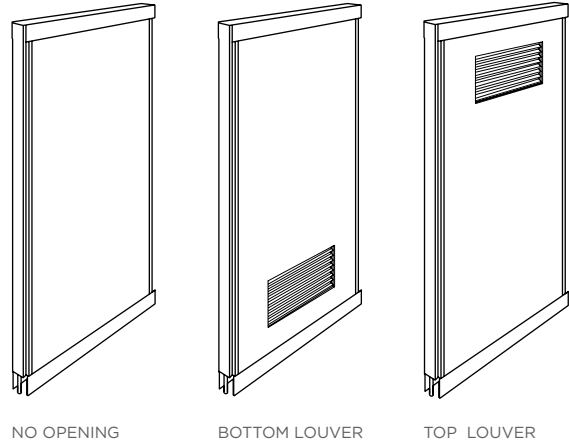

Filler Panels | Filler panels are installed at the

end of a panel run that meets a fixed wall. They accommodate window mullions, moldings, uneven wall conditions and irregular shaped conditions. Available in 6" to 48" widths in 6" increments, Filler Panels have a steel side rail on one end and an expanded polystyrene core that can be cut to fit conditions in the field. Wall Channel must be ordered to provide a clean finished transition to the building wall (part number TWC##). One wall channel should be ordered for every Filler Panel. A Ceiling Filler Panel is constructed identically to the corresponding Filler Panel below it.

NOTE: if Panels are specified with different Side 1/Side 2 fabrics or vinyls, consider the position of the Filler Panel in the panel run. Due to their construction (side rail on one end), Filler Panels will be handed with regard to the placement of the surface material (see right). Plan accordingly.

Ceiling Panels | In addition to the maximum 10' Panel height, Ceiling panels and Ceiling Filler Panels can add another 1' to 4' in height. Ceiling Panels are constructed using a welded steel frame with a thermafiber core and 3/8" (10) gypsum wall-board skins that can be laminated with vinyl or fabric. The minimum ceiling panel height is 1'. **NOTE: Ceiling Braces must be used at every door section and every 8' in the panel run.**

See page 16 for more information.

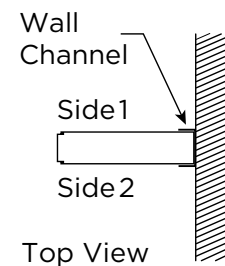
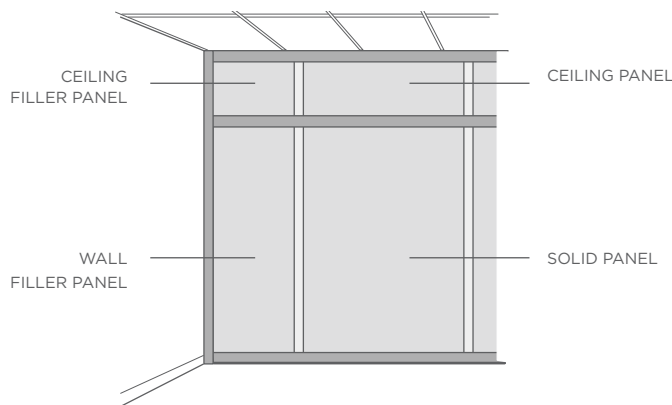

Glazed Panels | TrendWall Glazed Panels are constructed using the same welded frame and core materials as the TrendWall Solid Panels, but also include a framed opening. These panels are roll-formed steel frames with 22-gauge vertical and horizontal glass rails and dual durometer vinyl glass retainers that hold a 1/4"-thick sheet of tempered safety glass or other approved glazing material. Glazing can either be provided by Trendway or by a local supplier. A complete glass schedule is provided for all orders that ship without glass. Basic Glazed Panels DO NOT ship from Trendway with glazing already installed: glass or decorative glazing ships separately for field installation.

There are several glazing options for TrendWall Glazed Panels, including a factory direct options:

- GN - No Glazing provided
- G2 - Tempered Glass
 - T03 Clear
- G3 - Safety Glass
 - T04 Frosted
 - T05 Clear Laminated

TrendWall Glazed Panels are available with a variety of opening sizes and locations:

- Full Lite - the opening begins a minimum 9-1/4" from the bottom of the panel and ends 2-1/4" from the top.
- Door Height - the opening begins a minimum 9-1/4" from the bottom of the panel and ends at the chosen door height (80" or 84")
- Window Lite - the opening begins at 42-1/2" from the bottom of the panel and ends at door height.
- Hi Lite - the opening begins at the door height (80" or 84") and ends 2-1/4" from the top of the panel (2-1/4" of gypsum is at the top of all Hi Lite Panels) The minimum ceiling height for standard panels is 91-1/4" for an 80" (6'8") Door and 95-1/4" for an 84" (7') Door, which provides a 6-1/2" opening with a 6" piece of glass. **Note:** the minimum ceiling height for SPECIAL panels is 88-1/4" for an 80" (6'8") Door and 92-1/4" for an 84" (7') Door, which provides a 3-1/2" opening with a 3" piece of glass..
- Sliding Window Lite - the opening begins at 42-1/2" from the bottom of the panel and ends at door height. Can be specified with an optional shelf.

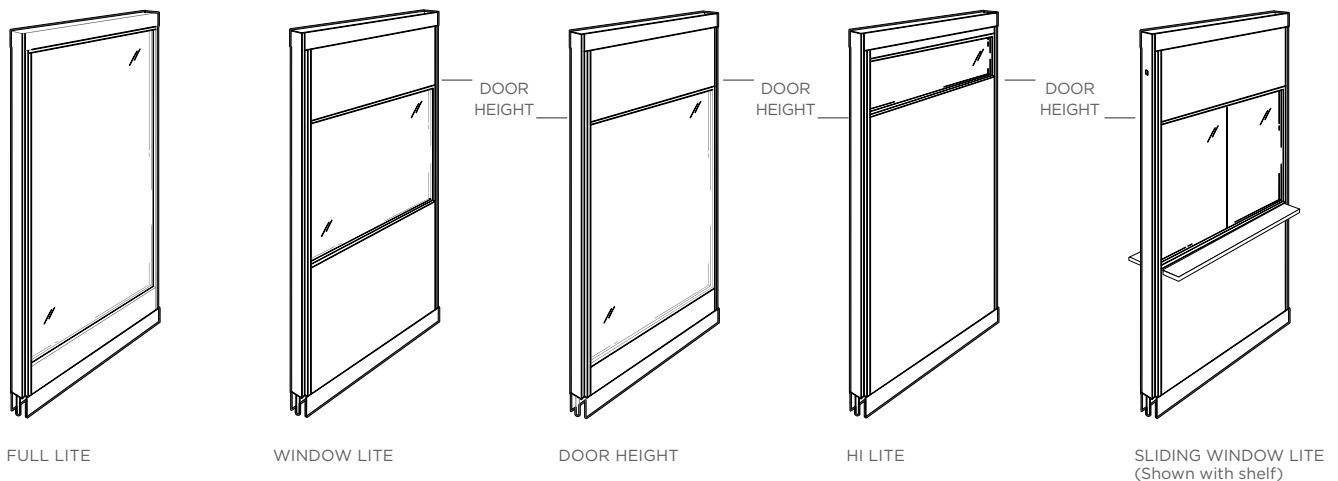

Glazed Panel Louver Option

Aluminum painted louvers can be added to any Glazed Panel at least 36" wide except Full Lite Panels. The Louver opening is 11" x 27". Louvers are powder-coat painted to match the chosen Trim Color.

- P1 - Aluminum Louver Top
- P2 - Aluminum Louver Bottom

Segmented Glazed Panel

Full Lite and Door Height Glazed panels have the ability to become Segmented by simply selecting the base panel style and specifying the number of segments in the Glazed Segment option string.

- S1 - 1 Opening
- S2 - 2 Openings
- S3 - 3 Openings
- S4 - 4 Openings
- S5 - 5 Openings

Example: To obtain a Door Lite panel with four segments, choose catalog number WPDG and add option S4.

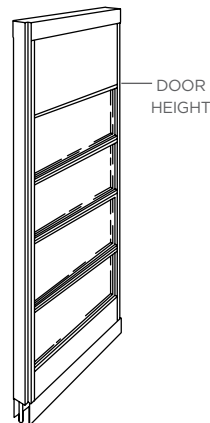

SEGMENTED DOOR HEIGHT (S4)

Glazed Ceiling Panel

Glazed Ceiling Panels are constructed using a welded steel frame with a thermafiber core with a framed opening to accommodate 1/4" glazing material. They are used in conjunction with lower panels to reach ceiling heights greater than 10'. **NOTE: Ceiling Braces must be used at every door section and every 8' in the panel run. See installation instructions INS077 for complete details.**

GLAZED CEILING PANEL

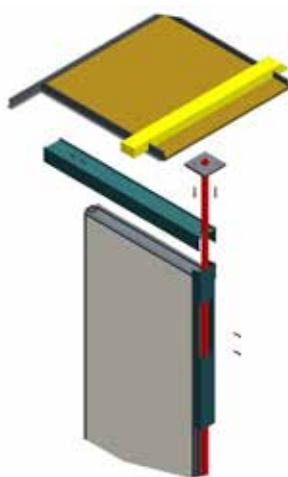
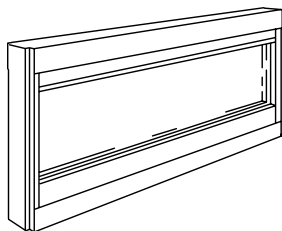

CEILING BRACE FOR END-OF-RUN CONDITIONS

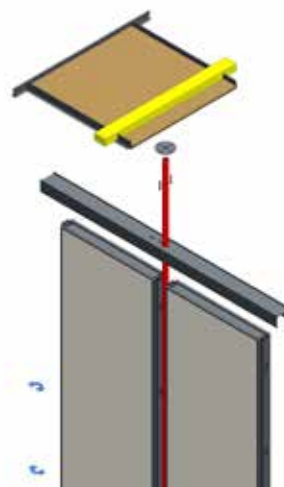

CEILING BRACE FOR PANEL-TO-PANEL CONDITIONS

Variable Glazed Panel with Custom Segments

TrendWall Variable Glass Panels with Custom Segments allow specifiers to select a different height, placement and glazing material for each individual segment in a panel. This is especially useful for designs requiring a segment of non-transparent material to provide a degree of privacy, or for a special sill height.

Customers can choose up to 5 segments per panel. Different catalog numbers apply according to the number of segments desired. Number of segments desired is specified as S1, S2, S3, S4, S5 as required, with the lowest segment in the panel always A1, the next lowest A2, etc. up to A5.

There are three basic categories of Variable Glass Panels with Custom Segments: Full Height, Door Height with Top Glass and Door Height with Top Solid. Example: To obtain a Full Lite panel with two segments, choose catalog number WPGF and add option S2.

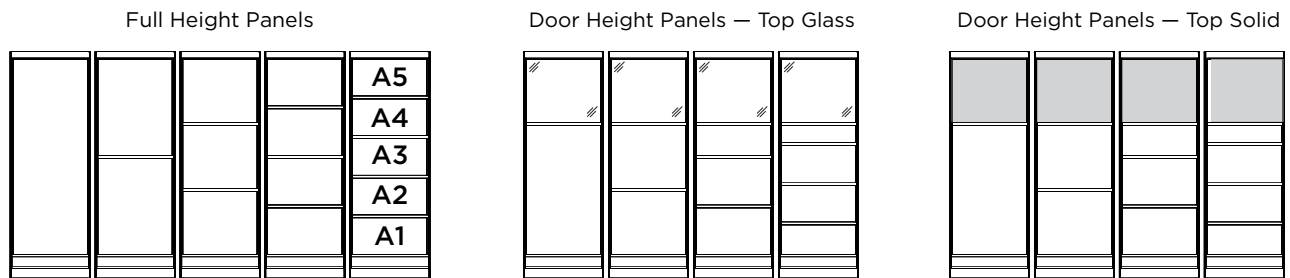

In order to specify these panels, you will need to determine the following:

1. Panel type from the 3 options above
2. Ceiling height
3. Panel width
4. The Sill height (minimum 9.25")
5. Glass Size Pricing Category for each section (8 categories, 1A - 1H, depending on the size)
6. The position (height) of each glass line, measured from the finished floor level

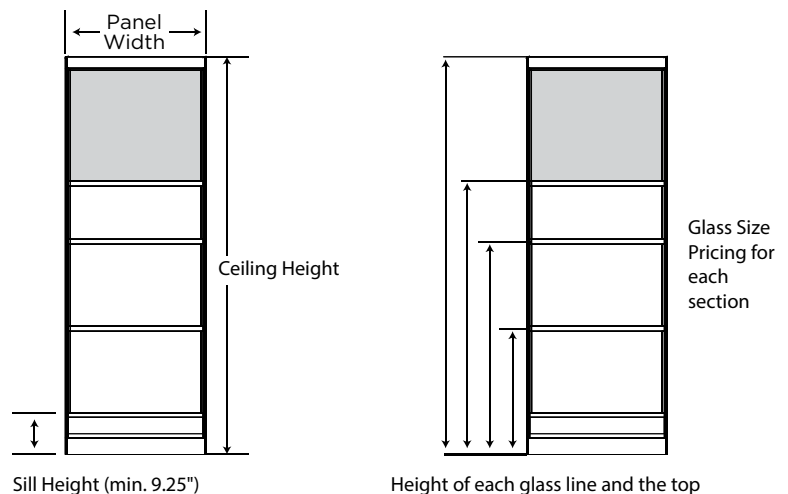

Catalog numbers for variable glass panels with custom segments will begin with one of the following: WPGV__, WPGVF__, WPGVD__, and end with S1, S2, S3, S4 or S5.

To easily determine the Glass Size Pricing category, use the Variable Panel Worksheet, located in the Products/Specifications - Training section of Trenddealer, under the Architectural Products category. This easy-to-use tool will generate the category for each segment to simplify final specification. [Click here to see it now.](#)

Door Sections and Doors

Door Sections | Standard Doors are 1-3/4" thick, vinyl or HPL surfaced and either 3' by 6'-8" or 3' by 7'-0", solid or hollow core. Door Panels are shipped with doors pre-hung in steel jambs with hinges and Lever Passage or Lock set. Six standard swing door styles are available: Flush, Flush with Standard Louver, Half Lite, Half Lite with Louver, Vision Lite, or solid core door with Full Lite (glass is shipped separately or sourced locally). If COM pulls or locksets are desired, Door may be specified as a BD (blank door) option (doors must be machined onsite). Note: glass molding and louvers match specified trim color. Doors can also be ordered separately.

Door Section Heights: Available in a variety of sizes to accommodate openings from 7' to 10' in height. Specify actual ceiling height in inches, using a decimal to represent fractions in 1/8" increments.

Door Section Widths (Nominal):

- Standard Sliding Door Section Width - 48" (including 8" side panel)
- Minimum Sliding Door Section Width - 42" (no side panel)
- Standard Swing Door Section Width - 48" (including 8" side panel)
- Minimum Swing Door Section Width - 40" (no side panel - 40-7/8" actual)
- Double Swing Door Section Widths - 84"
- Bi-Fold Door Section Widths - 48", 60" and 72"

Note: For conference rooms over 150 s.f. in size or any class room that holds 10 people or more, swing doors are typically required to meet national access and egress codes.

Louver and Transom Specification

- Swing and Sliding Doors: Glazed Transoms are ONLY available for a minimum ceiling height of 92" with a 6' 8" Door and 96" with a 7' Door.
- Swing and Sliding Doors: Louvered Transoms are ONLY available for a minimum ceiling height of 98" with a 6' 8" Door and 102" with a 7' Door.
- Swing Doors: Solid Transoms are not restricted as to ceiling heights.
- Sliding Doors: Solid Transoms are ONLY available for a minimum ceiling height of 85" with a 6' 8" Door and 89" with a 7' Door.

NOTE: Glazed Transoms are NOT available in any fabrics.

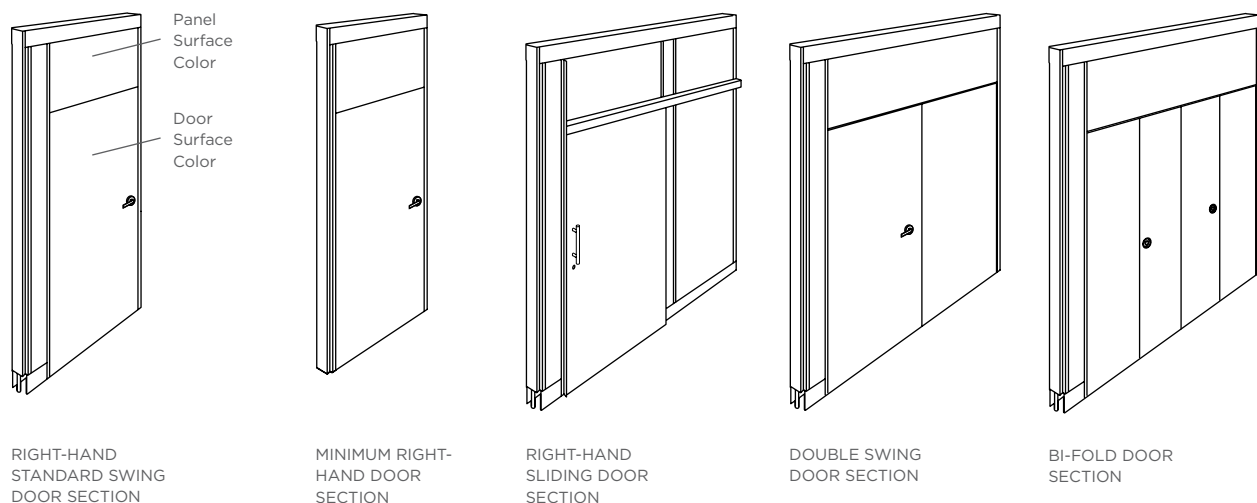

Swing Door Sections

TrendWall Door Sections are available in two styles: Standard Door Sections and Minimum Door Sections. Standard sections have an 8" side panel and are nominally 48" wide. Minimum sections do not have a side panel and are nominally 40" wide. Both can be specified with a factory pre-hung door, or without a door if they will be purchased locally. The door height must be specified when ordering Door sections, either 6'8" or 7'. As with TrendWall panels, you have the option of door sections with vinyl on one side and fabric on the other. NOTE: All Doors are ADA compliant, with a 32" clear opening.

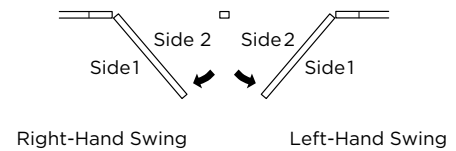

Door sections include a transom. Transoms can be specified solid, glazed or with painted metal louver. They may be vinyl or fabric covered. Side panels are also vinyl or fabric covered. Doors themselves must be finished the same on both sides. Doors are surfaced with either HPL or vinyl to match the trim color.

Note: See previous page for Transom specification details.

Sliding Door Sections

Sliding Door Sections are available as a space saving alternative to standard swing doors. They share the same 48" width as standard door sections and are available Flush/Solid or Full Lite only. Unlike Swing Doors, Sliding Door Sections need to be field assembled and installed. A Soft Close option is available as a service part.

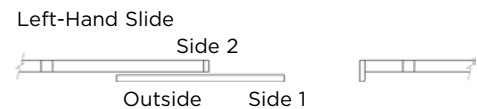
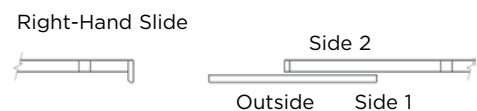

The doors can be specified as either LH or RH. The hand is determined by the direction the door slides to open. A RH door will open to the user's right when facing an exterior mounted door. ADA compliant Sliding Door Pulls come with a Satin Chrome finish. Specify actual ceiling height in inches using a decimal to represent fractions in 1/8" increments.

Note: See previous page for Transom specification details.

Double Swing Door Sections

Double Swing Door Sections create a 71" clear opening for both 72" and 84" Doors (opening by using one active door — the door with lever set) and one passive inactive door (the door with no lever set). Double Door Sections have the same factory options as Standard Doors, however, these doors require field assembly. Door panels, headers, jambs and hardware are all sent separately.

Specify actual ceiling height in inches using a decimal to represent fractions in 1/8" increments.

Bi-Fold Door Sections

Bi-Fold Door Sections can create a variety of storage areas within TrendWall installations. Bi-Fold sections come in only the flush door style with solid transoms. Like Double Door Sections, Bi-Fold Door Sections requires field assembly. Specify actual ceiling height in inches using a decimal to represent fractions.

Note: The actual Bi-fold door opening is 12" less than the nominal door section.

Standard Single Door

Standard single doors are 3' wide by 6'8" or 7' high by 1-3/4" thick. Specify left-hand or right-hand swing. Windows can be specified in a variety of sizes and shapes. Available in a choice of Vinyl or HPL surface colors.

Double Door

Double doors feature one active door and one inactive door, which is kept closed by a latch on the edge near the top and bottom. Unlocking the latch allows both doors to open, creating a 71" wide clear opening. Field assembly is required. Available in a choice of Vinyl or HPL surface colors.

Bi-Fold Door Panels | Ideal for storage, Bi-fold doors are double doors hinged in the middle to fold out of the way as they open. Field assembly is required. Bi-Fold Doors ship complete with 1-1/8" spherical brushed chrome knobs. Available in a choice of Vinyl or HPL surface colors. **Note: The actual Bi-fold door opening is 12" (305) less than the nominal door section.**

Find detailed dimensions on the following page.

SWING DOORS (Vinyl or HPL)

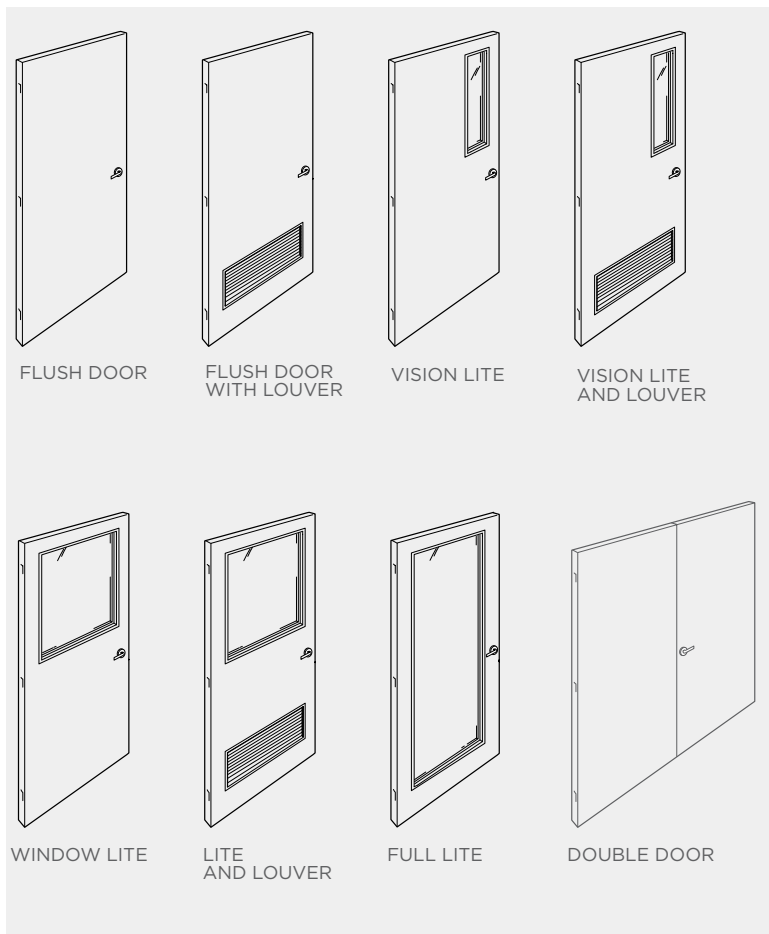

SLIDING DOORS (Vinyl or HPL)

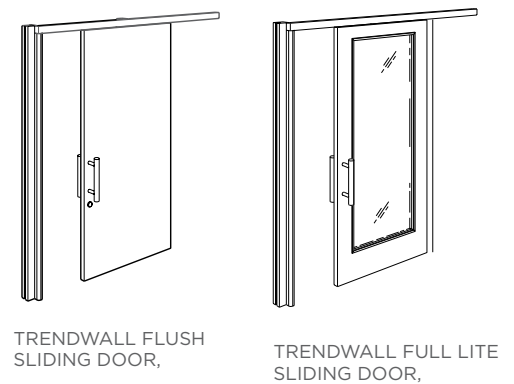

BI-FOLD DOOR (Vinyl or HPL)

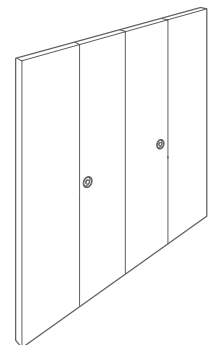

TrendWall Door Dimensions

Swing/Double Swing

Door Style	Door Type	Door Width (Nominal)	Clear Opening (Nominal/Installed)
Swing Door	Vinyl or HPL surface Swing Door (All)	36"	33"
Double Swing Door	Vinyl or HPL surface Swing Door (All)	72"	66"
Bi-Fold Door	Vinyl or HPL surface Bi-Fold	48"	36"
		60"	48"
		72"	60"

Sliding Door

Door Style	Door Type	Door Width (Nominal)	Clear Opening (Nominal/Installed)
Sliding Door	Vinyl or HPL Sliding Door (Flush/Solid, Full Lite)	42"	34"

Door Glazing

There are numerous ways to glaze both Swing and Sliding TrendWall Doors, including a factory direct option. All are field-installed.

- GN (No glass). If this option is chosen, no glass will be supplied. All 1/4" (6) material will need to be field installed. Trendway will supply a detailed glass schedule to facilitate this process.
- G1Z - Clear Tempered Glass
- G3Z - Safety Glass: Frost and Clear Laminated

Glass Dimensions, Swing Door

Actual Swing Door Size	Style	Glass Size
35.875" x 79.5"	Full Lite	24" x 66"
	Window	26" x 34"
	Vision	4" x 34"
35.875" x 83.5"	Full Lite	24" x 70"
	Window	26" x 38"
	Vision	4" x 38"

Glass Dimensions, Sliding Door

Actual Sliding Door Size	Style	Glass Size
41" x 79.5"	Full	24" x 66.875"
41" x 83.5"	Full	24" x 70.875"

Door Hardware | Swing Doors have an ADA compliant Lever Set. A locking version can be specified at an upcharge. Sliding Doors come with 18" Post Pulls and Locks. Door Hardware can be purchased separately. All Door Pull styles are available as Locking and Non-Locking. Locking is available Standard or Small Format Interchangeable Core (SFIC). SFIC locks are widely used where re-keying is frequent. New cores (COM) can easily be changed out as required. **NOTE:** Refer to Hardware Cut Sheets for specification details.

SWING DOOR PULL



ADA Lever Set — Lever Lockset shown, non-interchangeable lock, Brushed Chrome finish. Passage Set available.

SFIC OPTION



ADA Lever Set (SFIC shown — COM Core not included)

SLIDING DOOR PULL



18" Post Pull, Satin Chrome finish. 12" centerline to centerline of mounting hardware.

MORTISE LOCK



Standard Mortise Lock shown. SFIC Option available, COM Core not included.

IMPORTANT NOTE: Master Key Statement

Each end user needs their own unique Master Key system. It is most effective for a local locksmith to work with the client on their specific setup, so if changes or additions are required there is a nearby professional who understands their system and can address their future needs. For that reason, supplying master keyed products directly from Trendway is not in the best interest of the end user.

Trendway can provide blank cylinders, without keying, to assist in this process. If frequent changes are anticipated, an interchangeable core system should be used so the cylinder can be removed without disassembling the lock.

TrendWall Conditions

TrendWall Conditions are the connector kits that join individual panels together. These conditions include all necessary trim pieces and hardware to trim out and connect a TrendWall installation. Conditions may be specified in one of two possible styles: Standard and Enhanced. Standard Pilasters are designed to fit flush within the panel run and reveal the panel's side rail, while Enhanced Pilasters mount over the panel connection and cover the side rails to give a more monolithic aesthetic. Note: Enhanced Pilasters are not compatible with use of a Full Lite Sliding Door.

Connectors | TrendWall has one-piece connectors that slide into slots in the panel's side rails. Connectors are designed to accommodate the laying-in of electrical and communications wiring while still allowing the removal of the panel without disturbing the wiring. All panels are shipped with the connectors required for attaching one panel to another.

Corner Connectors will be included for each corner condition that is specified in the panel layout. If the layout requires angles other than 180° or 90°, you can specify the angle required on the order form. Where special requirements are needed, you should send a copy of the layout along with your order, noting the areas requiring special conditions. There will be an extra charge for these special conditions.

Straight Conditions | These conditions include two straight pilasters and panel connectors and are used to make an inline panel connection. Straight Conditions are available in both standard and enhanced versions. They can also be ordered with electrical punch-outs to accommodate either hardwire or modular power. Specify actual ceiling height in inches using a decimal to represent fractions in 1/4" increments.

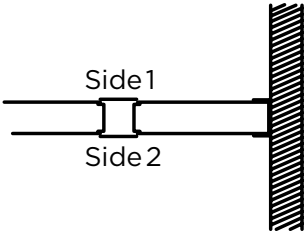
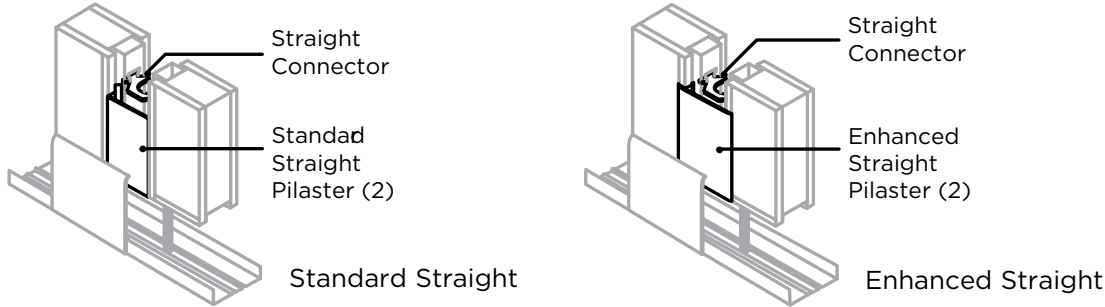

Top View

TrendWall Conditions

Corner Conditions | Corner Conditions include one outside corner pilaster cover, panel connectors, one crown corner and one base cover. Corner Conditions are used to create 90° corner in panel runs. Corner Conditions are available in both Standard and Enhanced versions. Note: Corner Conditions maintain centerline dimensioning.

Enhanced Extended Corner Conditions

Extended Corner Conditions include one outside corner pilaster cover, one inside corner pilaster, panel connectors, one crown corner and one base cover. Extended Corner Conditions are used to create a 90° corner in panel runs. Extended Corner Conditions are available in the Enhanced version only.

Note: Extended Conditions allow for inside room dimensioning (rather than center line dimensioning). Using Extended Conditions allow for standard sized freestanding furniture to fit within TrendWall layouts without increasing panel sizes.

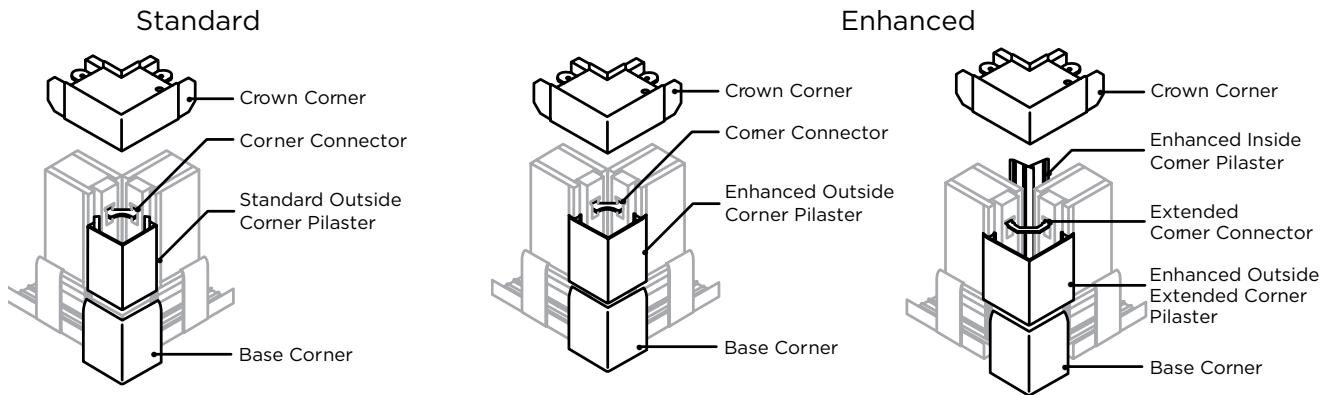

Angled Conditions | TrendWall allows specification of a standard 90° 2-way condition, plus virtually any angle within 72° of a straight in-line condition, as shown in the drawing. As with standard 90° 2-way conditions, the Standard Angle Condition (WCSAXX) comes with a mating crown corner (24" leg length). The service items (SITWCSAXX) do not include the mating crown corner. 30, 45 and 60 degree angled conditions do not require a drawing to be submitted; however, when specifying angled conditions other than 30, 45 or 60, a detailed scale drawing must be submitted.

Angled Wood Blocks

Angle Wood Blocks are available for attaching panels to a fixed wall at an angle other than a 90°. Detailed scaled drawings must be submitted when ordering.

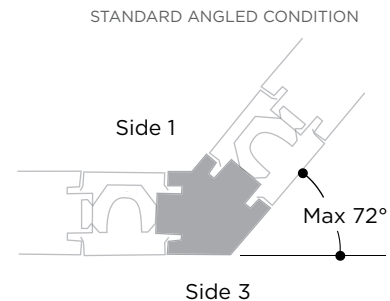

3-Way Conditions | 3-Way Conditions, commonly called “T” conditions, are used to create a 3-way panel connection in panel runs. They can be ordered with electrical punch-outs to accommodate either hardwire or modular power. Punch-Outs are available on the outside face only.

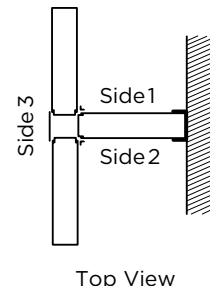

Standard 3-Way Conditions

Standard 3-Way Conditions include one standard straight pilaster cover and panel connectors.

Enhanced 3-Way Conditions

Enhanced 3-Way Conditions include one enhanced straight pilaster cover and panel connectors.

Note: 3-Way Conditions maintain centerline dimensioning.

Standard Half Extended 3-Way Conditions

Half Extended 3-Way Conditions include one outside straight pilaster cover, two inside corner pilasters and panel connectors. Note: Half Extended 3-Way Conditions create inside dimensioning in one direction..

Enhanced Half Extended 3-Way Conditions

Enhanced Full Extended 3-Way Conditions include one enhanced straight pilaster cover, two enhanced inside corner pilasters and panel connectors. Note: Extended 3-Way Conditions create inside dimensioning in both directions.

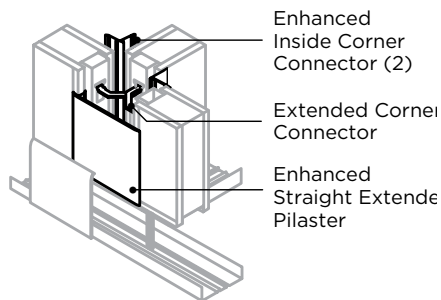

ENHANCED FULL EXTENDED 3-WAY CONDITIONS

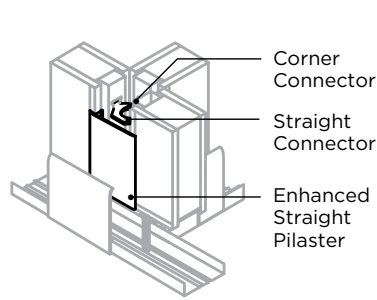

ENHANCED 3-WAY CONDITIONS

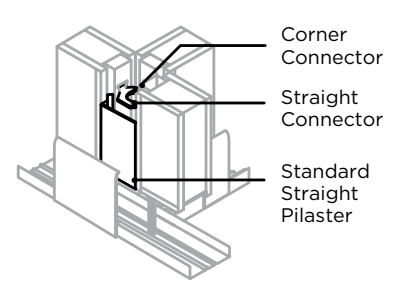

STANDARD 3-WAY CONDITIONS

4-Way Conditions | 4-Way Conditions include one steel pilaster, one wall channel and panel connectors. 4-Way Conditions are specified with Trim color only, as only the painted wall channel is seen.

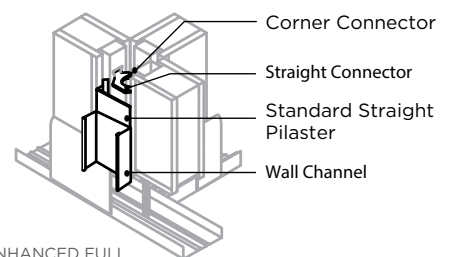

ENHANCED FULL EXTENDED 4-WAY CONDITIONS

Finished End Kits | Finished End Kits are used to create an end of run that does not abut an existing building element. They can be used in pairs to create archways. One kit includes a painted finished end, one crown cap and two vinyl door base ends. Specify actual ceiling height in inches using a decimal to represent fractions in one quarter inch increments.

Wall Channels | Wall Channels are used with a filler panel at the end of a panel run to create a clean finish against an existing building wall.

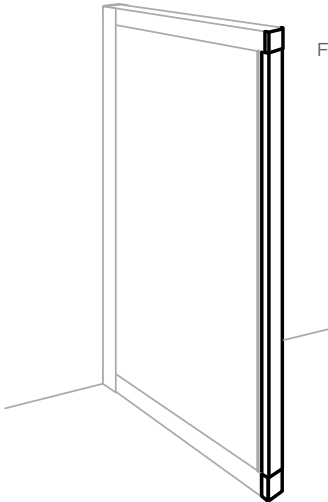

FINISHED END KIT

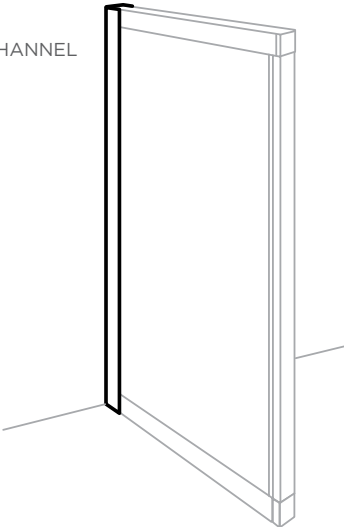

WALL CHANNEL

Pilasters

Pilasters are the finished covers designed to snap into place between the panels to conceal the panel connectors and wiring. They come in the same height as panels, ranging from 7' to 10' and from 1' to 4' for ceiling fillers. Pilasters are included with the specified Condition (see page 21). Pilasters are available with optional punchouts for switches, duplex receptacles and data communications.

Pilasters are available in Standard or Enhanced styles and are designed to snap into place between panels to conceal the panel connectors and wiring. Standard punchouts are available. Optional factory modification to pilasters is available to accommodate switches and duplex receptacles. Pilasters can be specified with Vinyl, Fabric or any of the standard and premium Trendway trim paint colors. Enhanced Pilasters are available in all vinyl finishes and all fabric colors, but they cannot be painted.

Standard Pilasters | Standard Pilasters fit between the panels, exposing the vertical painted side rails of the panels on each side of the Pilaster. Standard Pilasters are available for Straight or Outside Corner Conditions. Standard Pilasters are specified in one of Trendway's standard vinyl or fabric colors.

Enhanced Pilasters | Enhanced Pilasters are designed to cover the panel's metal side rails to give a continuous look to the panel run. Enhanced Pilasters are available as Straight, Outside Corner, and Inside Corner configurations. They can be specified in Vinyl or Fabric.

Enhanced Extended Straight Pilasters | Extended Straight Pilasters are available for use with the Extended Corner Connectors. Note: Extended pilasters can be used ONLY with extended conditions and are only available in the Enhanced style.

Corner Pilasters | Corner Pilasters are available in Standard, Enhanced, Extended and Inside Corner styles.

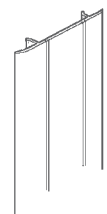
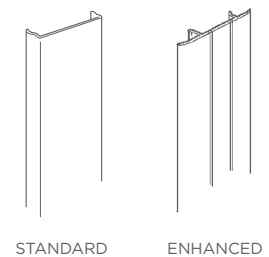
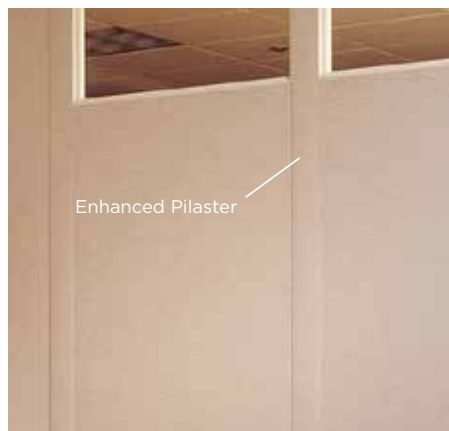

EXTENDED
ENHANCED STRAIGHT

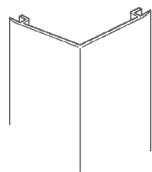

ENHANCED OUTSIDE
CORNER

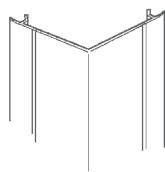

EXTENDED ENHANCED
OUTSIDE CORNER

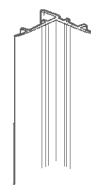

INSIDE CORNER

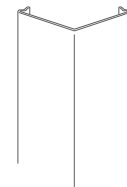

OUTSIDE CORNER

Punchout Pilasters | Pilasters can be punched to accommodate data communications and electrical access. The punch-out dimension is 2.7" x 1.38".

Note: Punch-out for Side 1 can not be the same as Side 2 for Switch and Data heights.

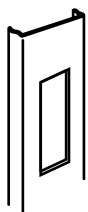

OUTLET / SWITCH /
DATA PUNCHOUT
(DECORA)

Punch-out Description:

Punch-out Description:

- C0 45" Switch Height with Box
- C1 45" Switch Height
- C2A 18" Standard Height
- C3 32" Work Height
- C4 6" Data Height
- C5A 18" Standard and 32" Work Height
- C6A 18" Standard and 6" Data Height
- C7 32" Work Height and 6" Data
- C8 Special Punch Out location
- AV 72" AV Height
- AVC5A 72" AV, 18" Standard and 32" Work Height
- AVC6A 72" AV, 18" Standard and 6" Data Height

Accessories

Accessories include Crown, Base and miscellaneous ceiling components, Sound Packing and Hardware items.

Crown, Base and Miscellaneous Ceiling Components

Caddy Clips

Caddy Clips may be used to attach the Crown to the ceiling grid. Use one every 2' (610) of Crown. **Caution: There will be a loss of 1/2" (13) to 5/8" (16) ceiling height adjustment when using Caddy Clips.**

Armstrong Silhouette Ceiling Clips

Available from Trendway (Special part number 404765)

Ceiling Grid Blocks

Ceiling Grid Blocks are finished stucco color. Specify either 3/8"-high x 7/8"-wide or 1/4"-high x 7/8"-wide., items TCH00K5, or TCH00K15. Special sizes available upon request.

Miscellaneous Connectors Ordered Separately

Ceiling brace to be used with cornice height walls. Includes ceiling bezel.

Individual items that are included with the panel price may be ordered separately, including:

Freestanding Stabilizing Block WB-10552

Crown Connector Plate TCCPLATE

Crown Alignment Plate. TCAPLATE

Ceiling Grid Block 3/8" TWGBLOCK38

Ceiling Grid Block 1/4" TWGBLOCK14

Crown Foam Tape SITW215

Panel Leveling Bolt SITLB

Straight Panel Connector TSCONNECTOR

Corner Panel Connector TCCONNECTOR

Extended Corner Connector TWCC1

Half Extended Corner Connector TWCC2

Positioning Tape TDFTAPE

Carpet Gripper Kit TCGRIP

Leveling Bolt Bracket SITLBB

Stabilizing Bracket SITSB

Sound Packing

Sound packing may be added to panel runs to enhance the overall STC performance of the wall. Sound Packing includes gasketing for use between crown and ceiling, and wall channels and walls. It also includes loose mineral fiber pieces to pack inside of base, crown, wall channels and pilaster cavities. Sound packing for ceiling fillers requires 50% (1/2) of the lineal footage of ceiling fillers. Sold by the lineal foot. **Note: Sound control results will vary based on grade of ceiling, floor coverings, draperies, duct work, etc. Note: Sound Packing is shipped separate from TrendWall panels and requires additional installation time.**

Gypsum

Individual square-edged sheets of vinyl or fabric covered gypsum. Will be shipped on pallets only. 25 pieces of 3/8" Gypsum board per pallet.

Fabric and Vinyl — Material Only

Fabric and Vinyl are available by the linear yard. Fabric width is 66"; Vinyl width is 62".

Touch-Up Kits

Touch-up paint for Trendway Trim colors are available in brush or spray can form. The Solid Vinyl Repair Kit can be used for minor repairs on vinyl wall surfaces.

Glass Molding

Glass Molding can be ordered in 12' lengths. Available in all standard Smooth trim colors.

Power and Data

TrendWall offers a robust capacity for routing and accessing power and data. The modular 8-wire PowerPac electrical system offers the power and flexibility of four circuits, one with a dedicated neutral and ground.

Modular Power | 8 Wire System

TrendWall's modular electrical system provides many pathways for accessing building electrical power and supplying it where and when it's needed. Power feeds, Power Modules, Power Harnesses and Duplexes all work together to supply power.

TrendWall's 8 wire 4-2-2 modular power system is identical in most respects to the rest of the Trendway family power components.

8-WIRE 4-2-2 POWERPAC
WIRING DIAGRAM

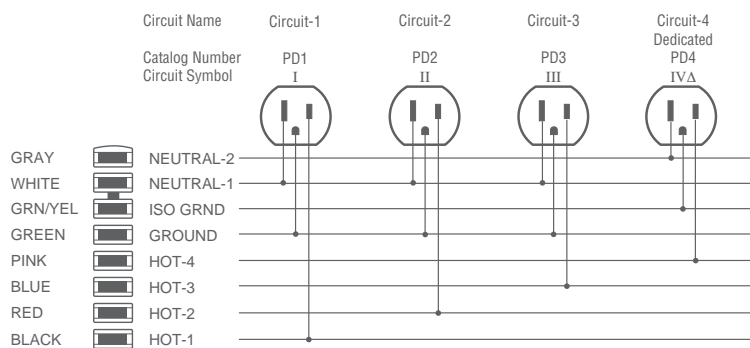

HARDWARE BOX KIT

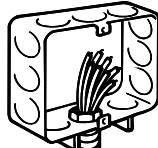
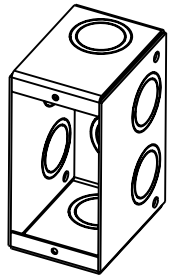

1-15/16" Unit Depth

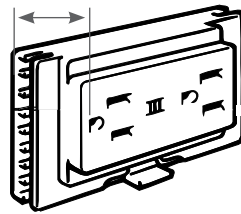

POWER DUPLEX

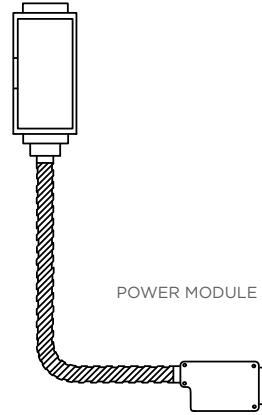

POWER MODULE

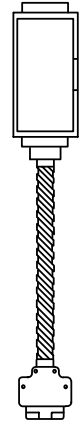

WORK HEIGHT ADDER POWER MODULE



CEILING FEED

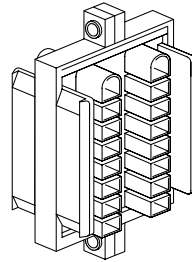

END BLOCK



PASS-THROUGH HARNESS



MALE/MALE HARNESS

Electrical Components

Hardwire Box: Appleton M1250. It is 2-1/2" deep x 3-3/4" high x 1-13/16" wide with 1/2" and 3/4" knockouts. UL Listed.

Ceiling Feed: Supplies power from the ceiling to the distribution block on the Power Module. Length is 12' of conduit with 13' of wire.

Power Module Power Modules are available in three styles to bring power access to the area between the panels at varying heights. One end has a connector for attachment to Power Harnesses and the other end has a distribution block to accept a Power Duplex, both sides back to back, Appleton M1250. It is 2-1/2" deep x 3-3/4" high x 1-13/16" wide with 1/2" and 3/4" knockouts. UL Listed.

Power Duplex: The TrendWall Power Duplex plugs into the distribution block on the Power Module to access the power circuit. Each Power Duplex is clearly marked for Circuit I, II, III or IVΔ access. Circuit IVΔ has an orange numeral and delta symbol Δ to indicate it accesses the dedicated circuit. Packaged in boxes of six of the same duplex.

Pass-Through Harness: Pass-Through Harnesses bring power from a feed point to a distribution point at a Power Module. Harnesses are available in lengths from 24" to 141" in 3" increments and 16" Male/Male Harness for connecting Power at 3- and 4-way panel intersections.

Male/Male Harness: One is required for each 4-way condition.

End Block: The TrendWall Electrical End Block (TEEB) provides necessary connectors at the end of a TrendWall Modular Electrical run. One is required at the end of a run.

Note: Hardwire Installations: Electrical boxes must be specified separately. However, Trendway recommends the use of one of the following: Appleton M1-250, Bowers 1-MBS, Raco 690, Steel City GW-125-C or equivalent.

TRENDWALL CABLE CAPACITY

Pilaster Plan View

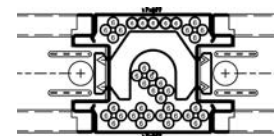

8 Bundles of 4, plus 5 = 41 Cat 6 Cables

Base Side View

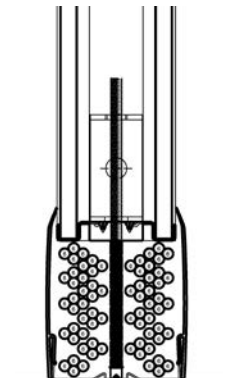

18 Bundles of 4 = 72 Cat 6 Cables

Electrical Planning

The TrendWall electrical system is routed through the base wireway and up or down through the connections between panels. Power is distributed from panel-to-panel or a run of panels by the use of Pass-Through Harnesses. Pass-Through Harnesses are available in lengths of 24" to 141" in 3" increments. Power Modules are plugged into the Pass-Through Harnesses to provide power to the plug-in duplex receptacles. The SITCFTP Ceiling Feed supplies power from the ceiling or floor to the distribution block on the Power Module.

Power Modules are available in two heights; 18" on-center from the floor for standard height and 32" on-center from the floor for work height access above a work surface. An optional work height adapter is available to extend power from a standard height module to work height. Power Modules attach between panels in standard width Straight Connections only. They will not attach in extended conditions.

Electrical Planning Summary

These steps outline the planning process:

1. Measure the ceiling height throughout the space to be sure of ordering the correct panel height.
2. Measure area to be enclosed by TrendWall, including door and glazed panels.
3. Plan components, doors, and optional panels to meet requirements of each office.
4. Develop elevations of each office, showing placement of components, doors, etc.
5. Develop an electrical layout to show the placement of electrical switches, receptacles, etc.
6. Trendway will figure widths of panels, hardware needed and POWERPAC electrical components. Plans will be returned to you for your review, to be signed and returned.

Typical electrical layouts shown for illustration purposes.

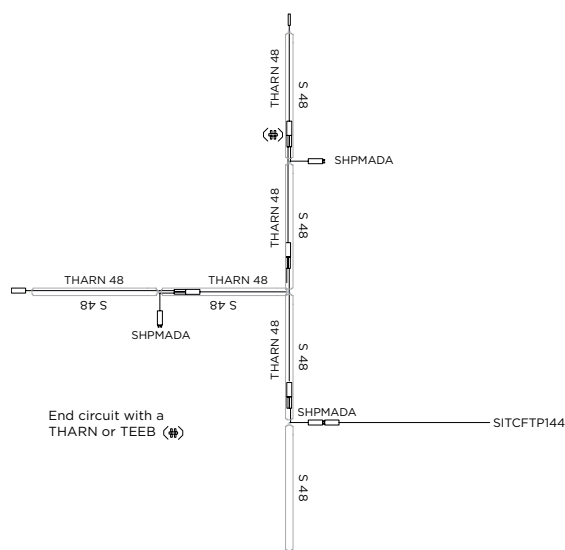

3-WAY MODEL

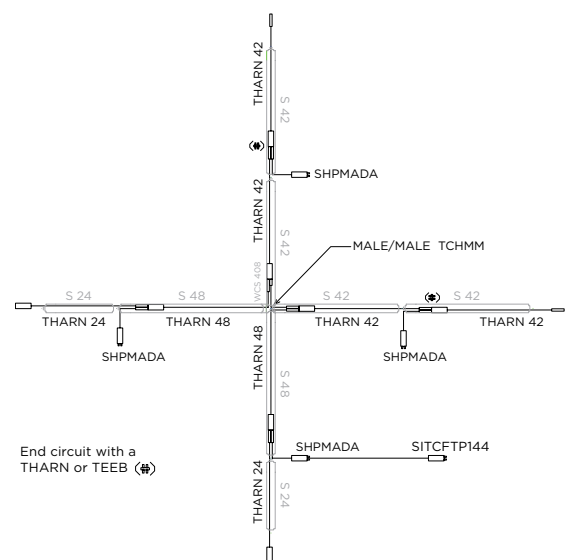

4-WAY MODEL

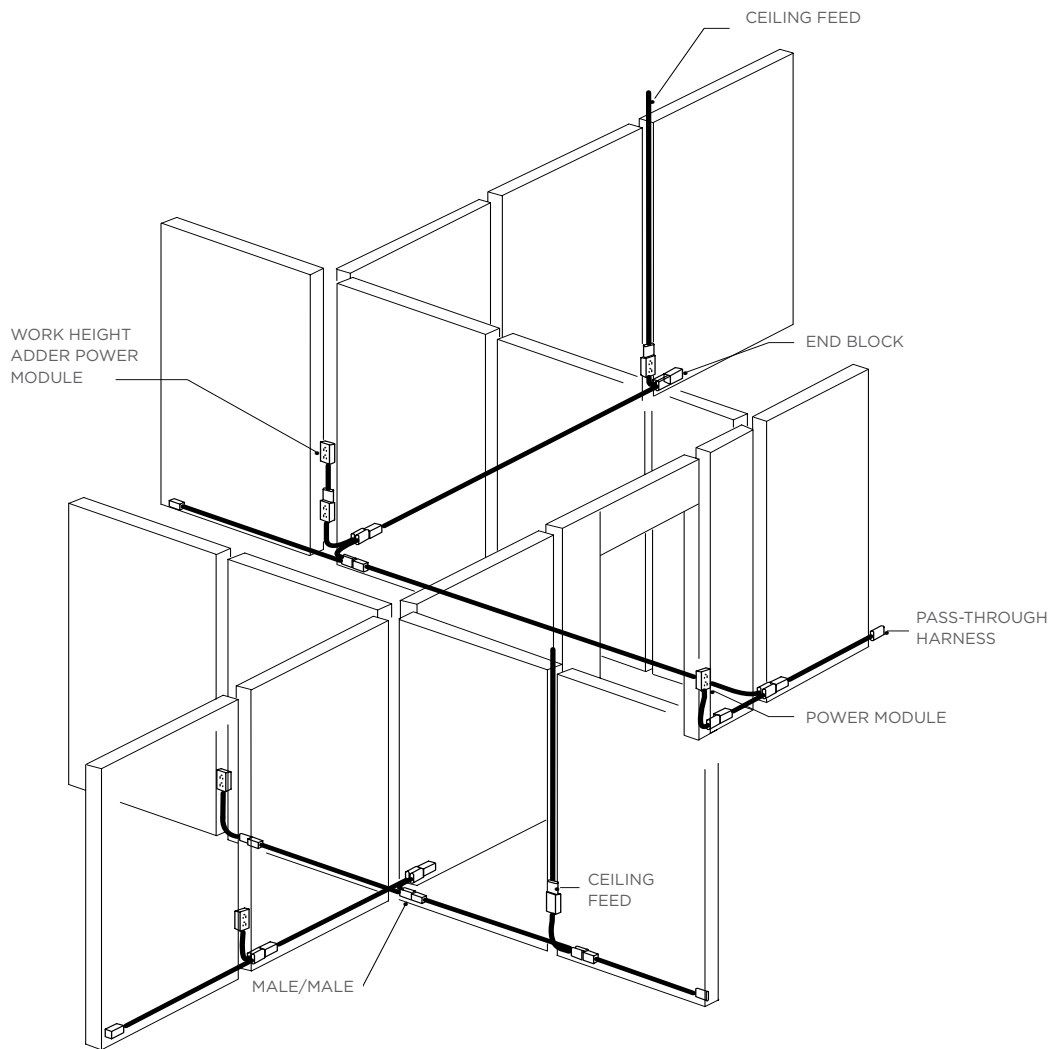

Hardwire Option

TrendWall Panels can be hardwired, if required, by routing conduit through the base wireways and run either up or down through the connections between panels. Electrical outlets and switches are mounted in junction boxes attached to the conduit.

Switches and receptacles are accessed through punch-outs in the pilasters. Pilasters are available with a switch punch-out located 45" on-center from the floor. If switches are to be back-to-back on a pilaster, one must be specified with a punch-out located at least 5-3/8" above or below the other punch-out. The same would be required for a receptacle punch-out. Receptacle punch-outs are located 18" on-center above the floor. Electrical boxes are not included, however, Trendway recommends the use of one of the following: Appleton M1-250 (orderable through Trendway catalog #SITMI250), Bowers 1-MBS, Raco 690, Steel City GW-125-C or equivalent. Electrical conduit and hardware must be supplied and installed by a local electrician

Acoustics

Acoustics 101 | The basics.

- You need to strike a balance between how much sound and how much silence is right for your space.
- Acoustics are described in several ways:
 - **Noise Reduction Coefficient (NRC)**, a single-number rating used in specification and product descriptions to show the sound-absorbing capabilities of a particular material. A material is classified as a sound absorber if it has an NRC value of at least 0.40. Porous materials, like fiberglass batt, have high NRC ratings.
 - **Sound Transmission Class (STC)**, a single number system used to rate the airborne sound transmission performance of a product like a wall, panel or ceiling. The higher the STC number, the better the product's ability to block sound transmission. Specifiers should not assume that a panel or partition with a higher STC rating is functionally better than one with a slightly lower rating, because a two- or three-point difference in STC ratings is not detectable by the human ear.
 - **Noise Criteria (NC)** is the measurement of background noise in specific interior environments. Because too much quiet can be as distracting as too much noise, the ideal work environment provides a healthy balance between the two.

Typical Background Noise Levels

Boardroom	NC -30
Auditorium	NC -30
Video/conference room	NC -30
Typical conference room	NC -30
Private office	NC -35-38
Open plan office	NC -38-40
Public areas	NC -40-55

- **Speech Privacy Potential (SPP)** is the measurement of how much privacy can be achieved from one area to another. SPP is calculated by adding together the STC and NC ratings. As shown in the chart below, an SPP less than 60 provides no privacy, while an SPP of 85 provides maximum privacy.

Privacy Rating	SPP Potential	Description
Total privacy	85	Shouting is barely audible.
Highly confidential	80	Normal levels not audible. Raised voices barely audible but not intelligible.
Excellent	75	Normal voice levels barely audible. Raised voices audible but mostly unintelligible.
Good	70	Normal voices are audible but unintelligible most of the time. Raised voices are mostly unintelligible.
Fair	65	Normal voices audible and intelligible some of the time. Raised voices are intelligible.

ACOUSTIC PERFORMANCE AND TRENDWALL | TrendWall has the capacity to provide acoustic privacy as good as or surpassing drywall. As a general rule, average conventional drywall has an STC rating range of 36 to 42.

TrendWall STC Ratings

Solid Panels

- Monolithic Solid Panel STC 39 (without additional sound packing in pilaster and base cavity)
- Monolithic Solid Panel STC 42 (with additional sound packing in pilaster and base cavity)

Glass Panels

- Monolithic 1/4" Tempered Glass STC 30

Speech Privacy Performance

Adjoining Area	NC	SPP	Privacy
Public Areas	40-45	80-85	Total Privacy
Open Plan Offices	38-40	78-80	Highly Confidential
Private Offices	35-38	75-78	Excellent

Office Partition Construction and Performance Levels

Other Construction Method	STC
Drywall partition up to acoustical ceiling line	STC -30
Drywall partition through acoustical ceiling 6"	STC -35
Drywall partition with insulation, full height up to slab	STC -40-45
Multiple layered drywall with insulation, full height up to slab	STC -45+

Tips for maximum audio privacy with TrendWall:

- If glazing is required, specify Laminated Glass.
- Rectangular spaces diffuse sound better than square ones.
- Select Swing Doors vs Sliding Doors.
- For peak privacy, TrendWall should be paired with acoustical ceiling tiles that have a minimum CAC or CSTC rating of 40 and a minimum NRC rating of .65.
- Batt insulation can also be inserted above the ceiling tiles over a TrendWall office.
- Select solid core Doors vs hollow core

Installation

Trendway field support

Trendway offers Field Technical Support for a nominal fee. Approved Trendway Technicians can take field measurements, train and assist during the actual installation at the customer location. Using this resource assures accurate product design and planning, as well as fast, expert installation. Contact the Trendway Architectural Product team for more details.

Please note: This is an overview summary of a typical installation. Every project is different. Detailed installation drawings and instructions are available on Trenddealer.

Important: Inspect the contents of all containers for shipping/handling damage. Make sure you have all required parts before proceeding.

Recommended Installation Tools

Saws

- Hole Saw for Metal — 1"
- Miter Saw 10" or 12" with 80 to 100 Fine Tooth Aluminum Cutting Blades
- Portable Band Saw with Extension Cord
- (18 or 24 Tooth Blade)
- Reciprocating Saw or Jig Saw with 4 -1/2" Metal Cutting Blade

Tools

- Allen wrenches - Standard and Metric Set
- Channel Lock Pliers
- Cordless Drill with Phillips Head Driver Bits - #2 and #3
- Counter sink metal drill bit
- Drill Bit Set with long 1/8" drill bit
- File
- Hammer Drill
- Masonry Drill Bits — 5/32" and 5/16"
- Nut driver — 1/4" and 5/16" (magnetic preferred)
- Nylon Mallet
- Putty Knife — 2" and 6"
- Quick Clamps — set of (2)
- Screw driver — 1/8" Flat Head
- Steel Hammer
- Tin Snips (set)
- Utility Knife
- Wrench — Open end wrench - 3/4" 15 mm (as thin as possible) or Crescent wrench

Other

- Ladders — 2' to 6'
- Level (4' preferred)
- Masking Tape
- Plumb Bob (Laser preferred)
- Saw Horses with drop cloth
- Combination Square
- Tape Measure - Steel
- Glass cleaner and Paper towels
- Glass Suction Cups
- Safety Glasses
- Shop Vac/Vacuum

Detailed, illustrated Installation Instructions, technical Cut Sheets and an Installation Training Video are available on Trenddealer or in the [on-line AP Binder](#).

Doors, Bi-Fold

TrendWall Closet	INS003
Bi-Fold Doors	INS075
Closet Kit.....	INS229

Doors, Sliding

Sliding Door	INS400
Sliding Door Kit.....	INS404
Sliding Door Soft Close	INS612
Post Pull.....	INS651

Doors, Swing

Double Door (Section) Jamb and Double Door	INS076
--	--------

Electrical

Electrical	INS172
------------------	--------

Panels

Cornice High Panels and Ceiling Filler	INS077
Floor-to-Ceiling Panels	INS138
Crown Filler Block.....	INS217
Picture Hanger	INS341
Split Wall Channel	INS344
Sound Packing	INS378
Sliding Glass Track/Shelf.....	INS413
Skin Replacement Panel Disassembly	INS495
AeraMax Pro.....	INS679



CORPORATE | Holland, Michigan | 616.399.3900 | Trendway.com

CHICAGO | LOS ANGELES | WASHINGTON, DC